

Clock

Introduction

The digital clock soldering kit offers the possibility to assemble your own functional clock with an integrated thermometer.

Assembly requires a soldering station or a soldering iron to melt solder at temperatures between 250 °C and 350 °C. **Special care must be taken to avoid burns during the process.**

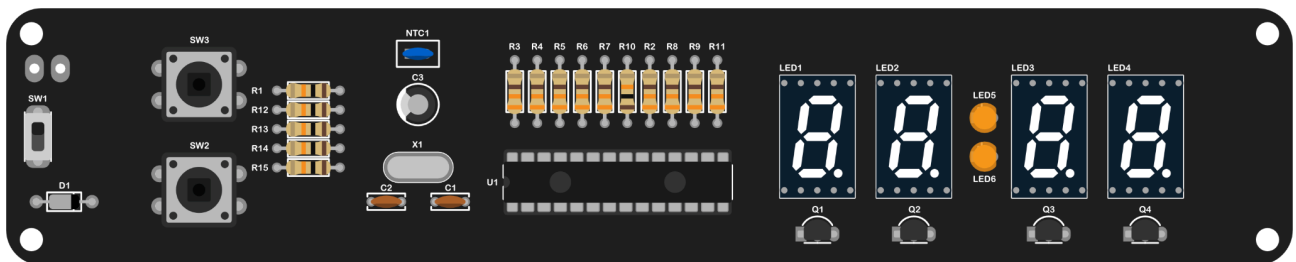

Circuit Diagram

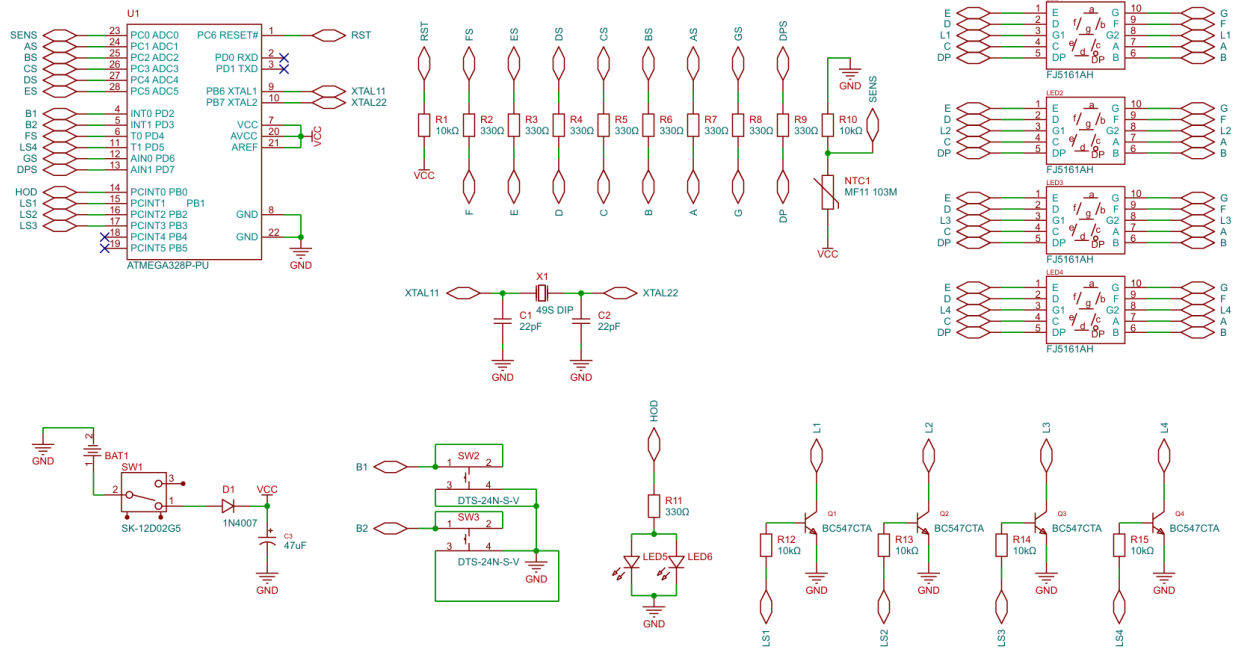

Parts List

Before starting, verify that all listed components are included.

Designation	Component	Details	Qty
R1, R10, R12-R15	Resistor	10k	6
R2-R9, R11	Resistor	330R	9
C1-C2	Capacitor	22pF	2
C3	Capacitor	47uF	1
Q1-Q4	Transistor	BC547	4
LED1-LED4	Segment display	-	4
LED5-LED6	LED THT	-	2
D1	Diode	-	1
SW1	Switch	-	1
SW2-SW3	Button	-	2
DIL28	Socket	-	1
U1	Microprocessor	ATmega	1
NTC1	Thermistor	-	1
X1	Crystal	-	1
BAT1	Battery holder	-	1
DPS	Printed circuit board	Clock	1



R1, R10, R12-R15

Resistor

6 pcs
10k

R2-R9, R11

Resistor

9 pcs
330R



C1-C2

Capacitor

2 pcs
22pF

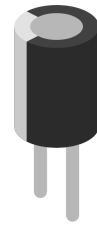

C3

Capacitor

1 pc
47uF

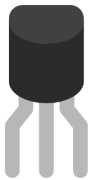

Q1-Q4

Transistor

4 pcs
BC547



SW1

Switch

1 pc

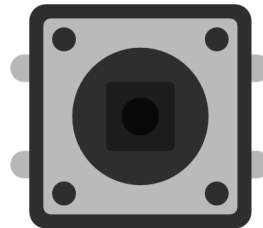

SW2-SW3

Button

2 pcs



D1

Diode

1 pc



U1

Microprocessor

1 pc

DIL28

Socket

1 pc



LED5-LED6

THT LED

2 pcs



LED1-LED4

Segment

4 pcs



BAT1
Battery holder
1 pc

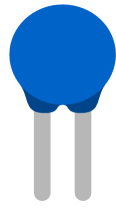

NTC1
Thermistor
1 pc

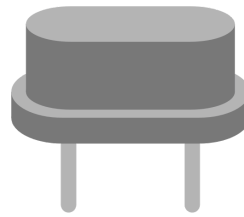

X1
Crystal
1 pc

Assembly

Resistors

The first components to be mounted on the printed circuit board are resistors **R1-R15**. The orientation of the component does not matter during mounting; it will function the same in both directions. Note that resistor **R10** has a different value from the other resistors.



R1, R10, R12-R15

10k



R2-R9, R11

330R

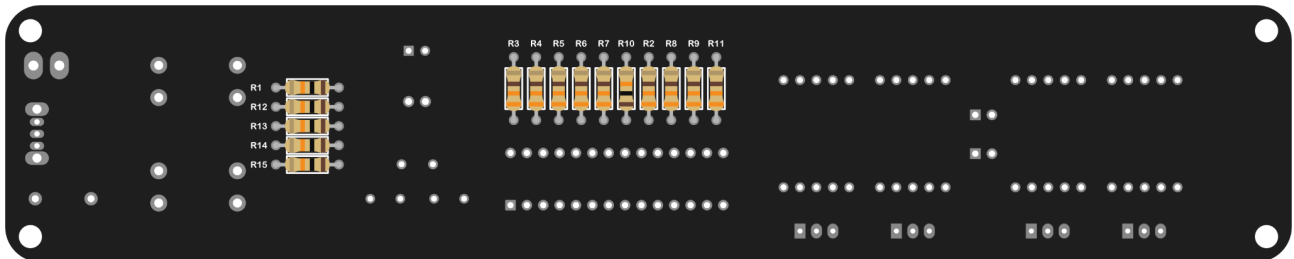
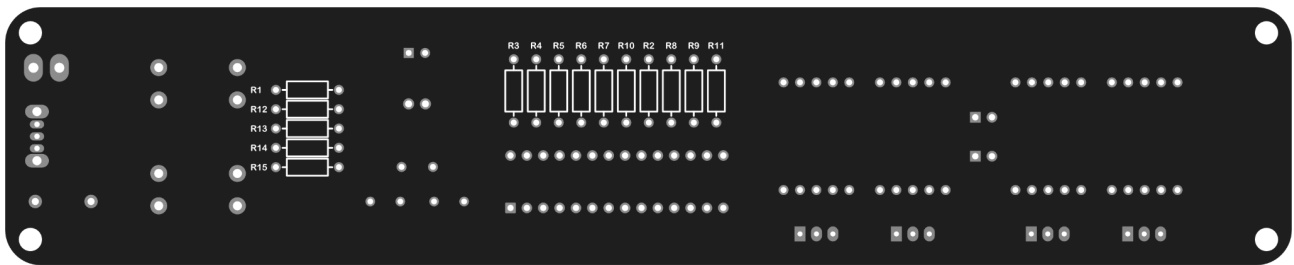

Diode

Observe **correct polarity when soldering D1**.

The diode has a marking stripe on one side, which is also visible on the PCB.
This stripe helps with correct orientation.



D1

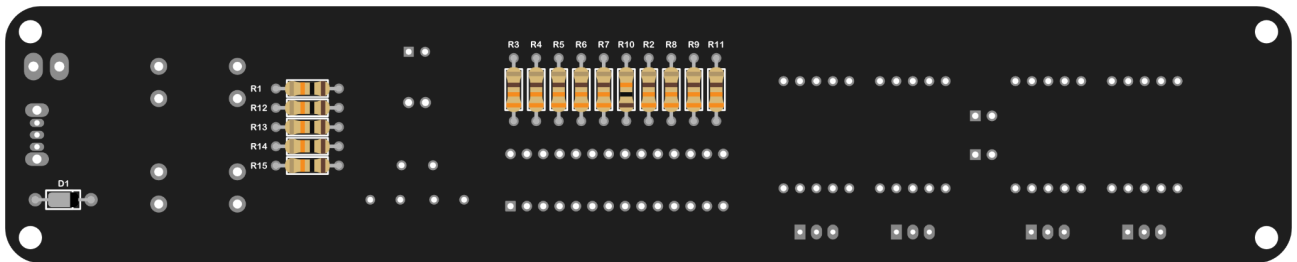
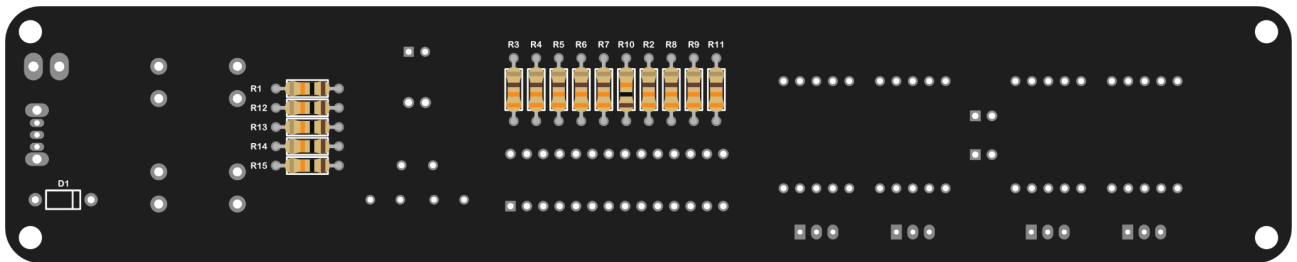

IC Socket

The microcontroller U1 is a sensitive component and can be easily damaged by heat.

Therefore, it is not soldered directly but placed into an **IC socket**.

When soldering the socket, pay attention to the notch on one side.

This **notch indicates the correct orientation** and must align with the marking on the PCB.

Do not insert the microcontroller at this stage!

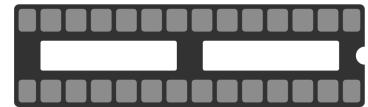

DIL32

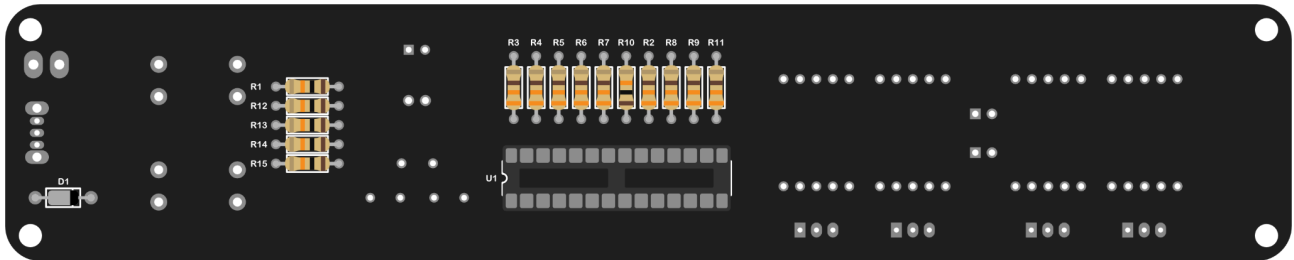
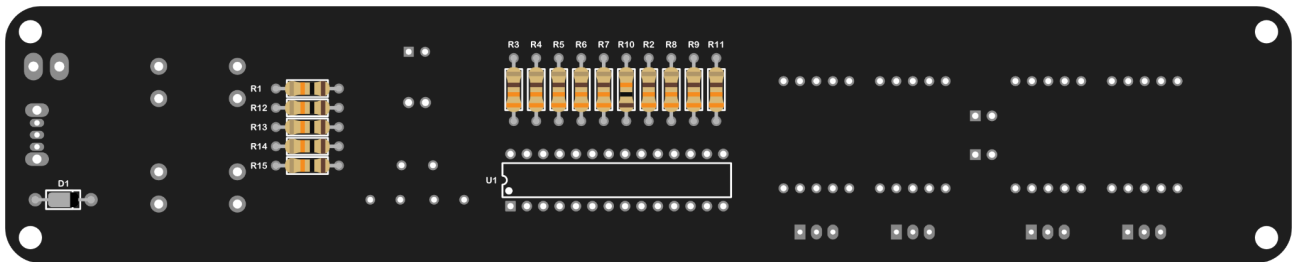

Capacitors

C1-C2 are **ceramic capacitors**—orientation does not matter.

C3 is an **electrolytic capacitor and must be soldered with correct polarity.**

Correct orientation is indicated by markings on both the PCB and the capacitor.

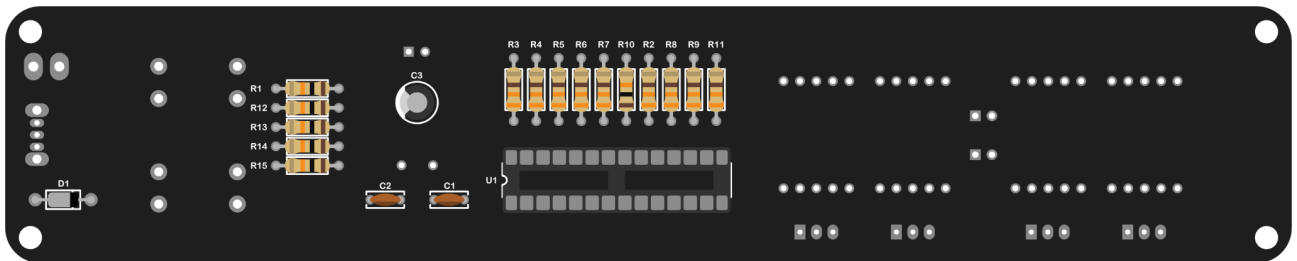
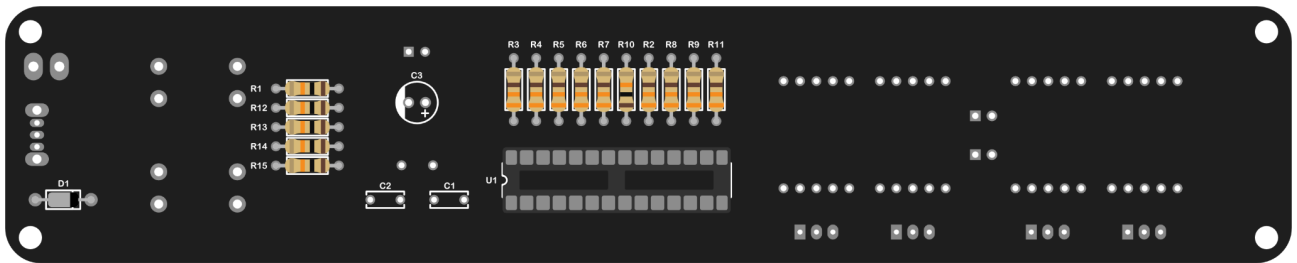
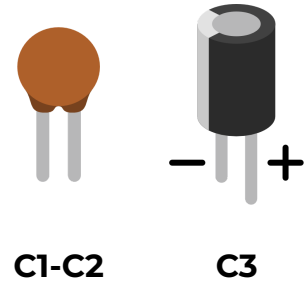

Thermistor

Like capacitors **C1** and **C2**, thermistor **NTC1** has no polarity, so it does not matter how we orient it.

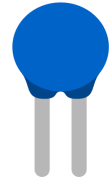

NTC1

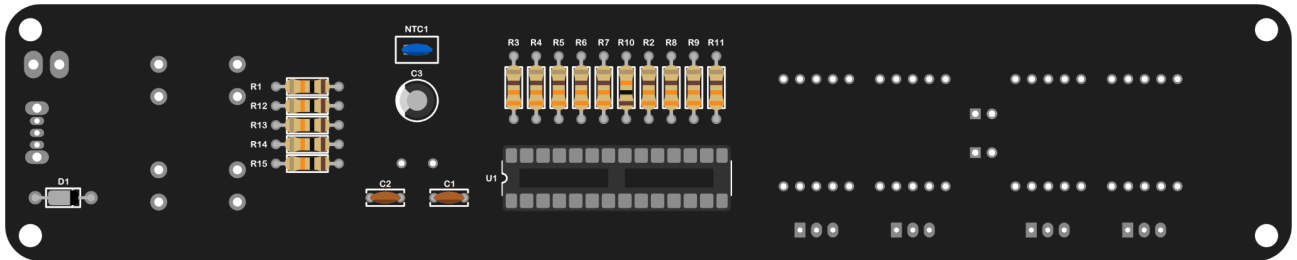
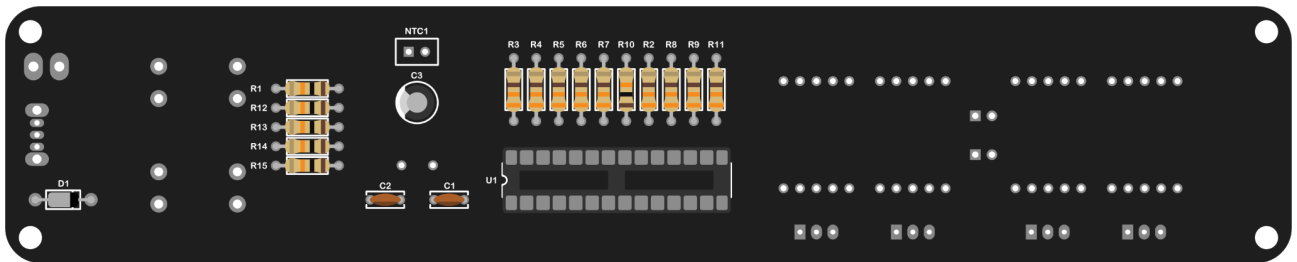

Button

The **SW2-SW3** buttons are mounted according to the drawing on the printed circuit board; turning the button does not affect its functionality.

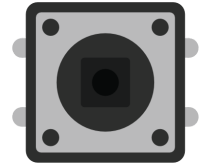

SW2-SW3

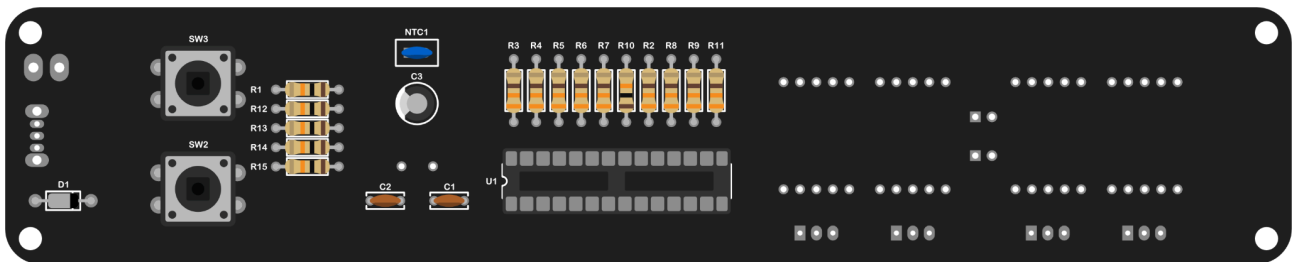
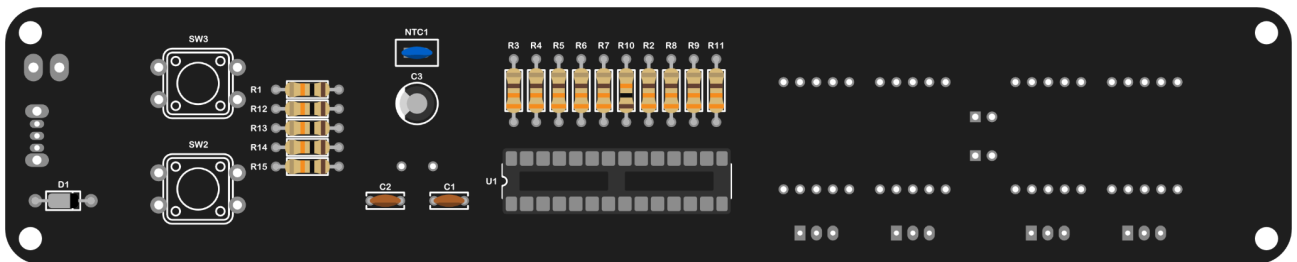

Switch

Next, we connect switch **SW1**. It also has no defined polarity, so we can connect it in either direction.



SW1

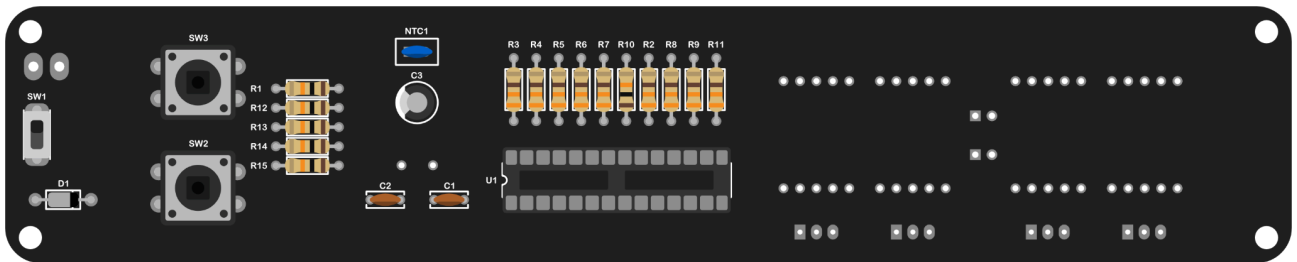
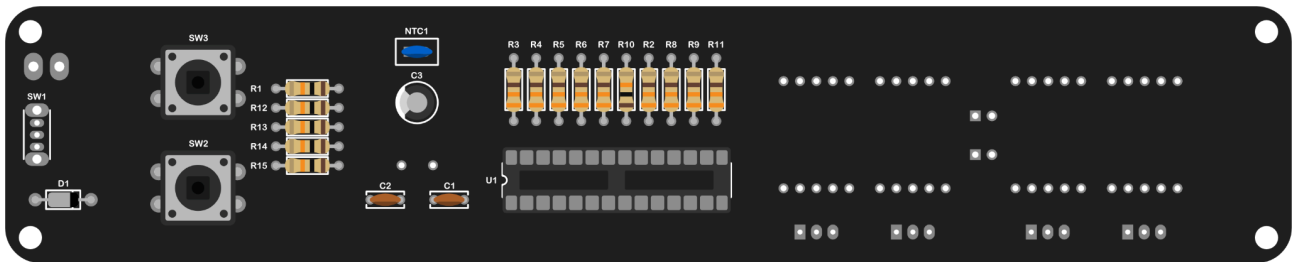

Segment display

LED1-LED4 displays are soldered in much the same way as integrated circuit sockets. First, place the component on the board so that its entire surface is flat against the board. Then start soldering its legs.

It is best to start with the upper left and lower right legs, as this will secure the component and prevent it from moving while soldering the remaining legs.



LED1-LED4

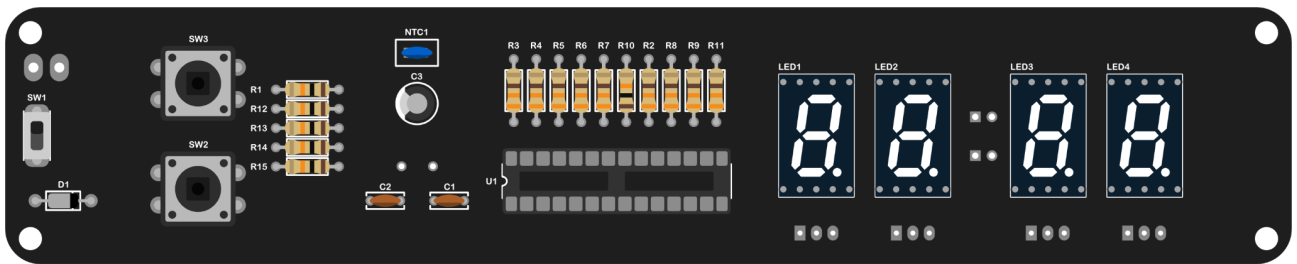
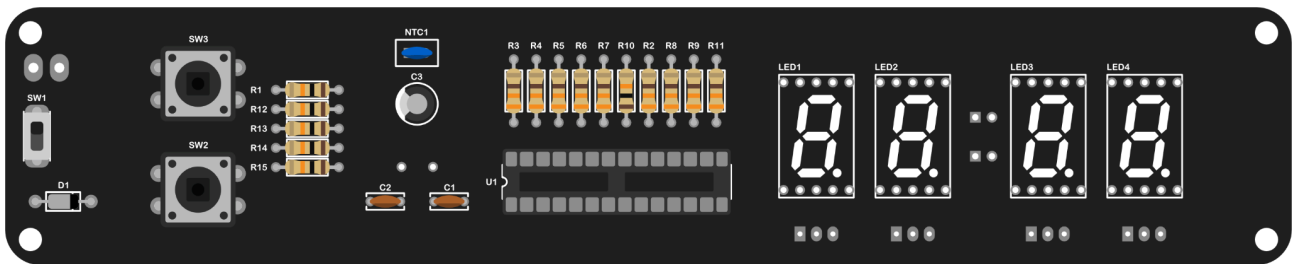

LED

Now we will install the THT diodes **LED5-LED6**. When installing, make sure that you place the diode correctly and that the polarity is correct.

The short leg on the diode is negative, the long leg is positive. So we will put the long leg into the square hole marked with a plus sign.

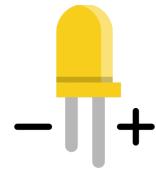

LED5-LED6

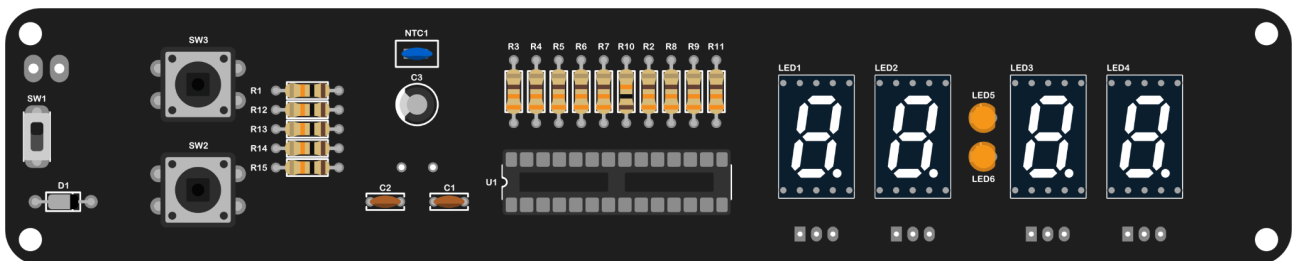
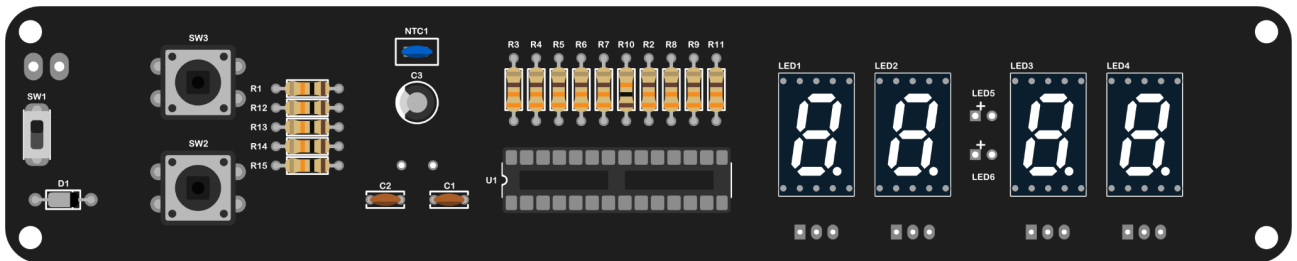

Transistors

Transistors **Q1-Q4** are very sensitive to heat damage, so we will solder the pins one by one and take longer breaks between soldering.

The polarity of the transistor is indicated on the board by an **arc**. This must correspond to the shape of the transistor.

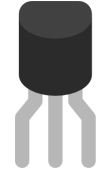

Q1-Q4

BC547

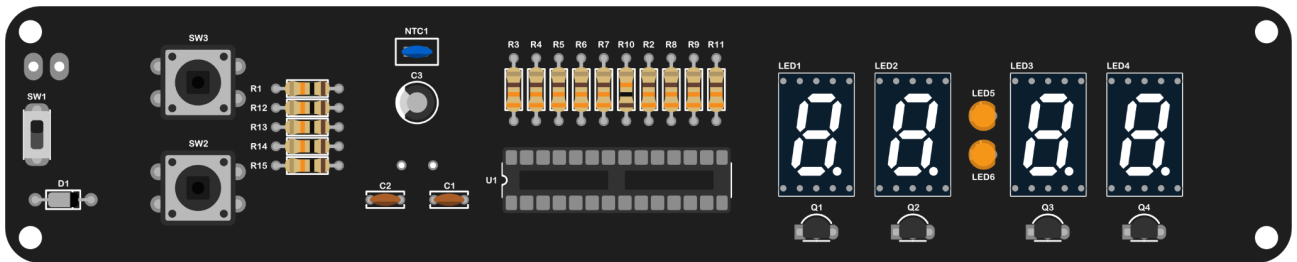
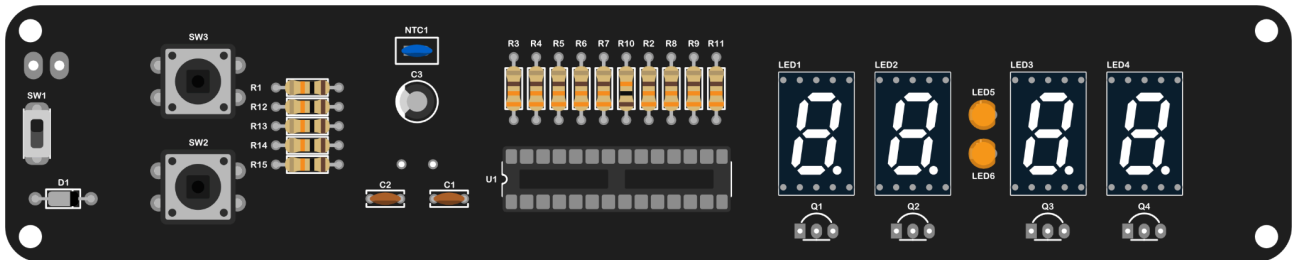

Crystal

Component **X1** is susceptible to heat damage, so we solder it carefully and only at short intervals.

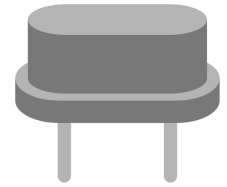

X1

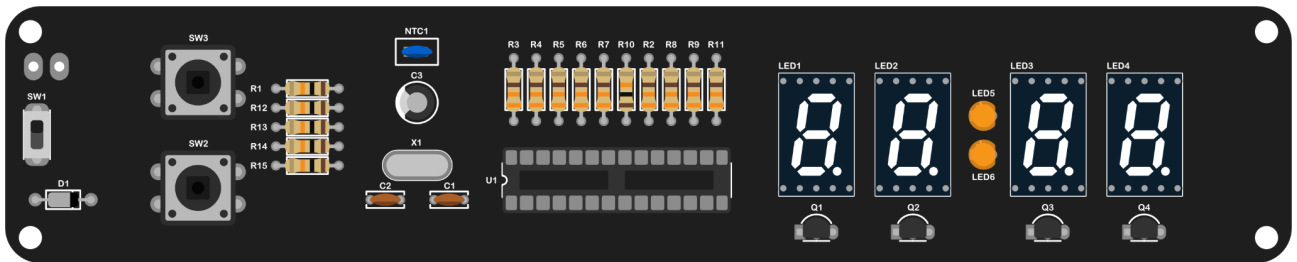
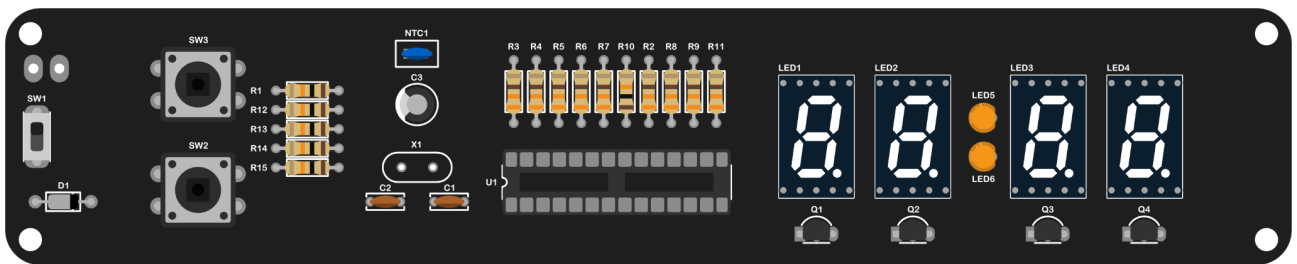

Battery Holder

The **BAT1** battery holder is mounted from the back of the board. When soldering, pay special attention to the surrounding components so as not to damage them. Connect the red cable to the hole marked with a plus sign.

We are not inserting the battery yet.



BAT1

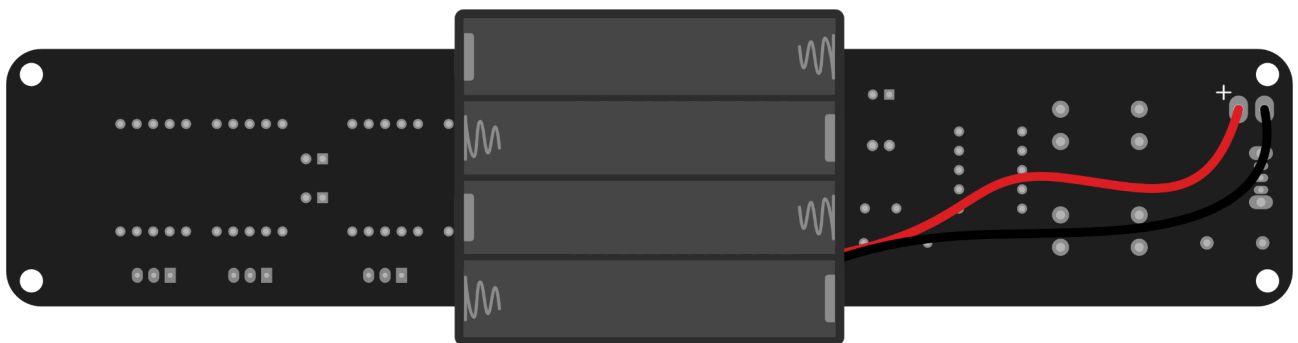
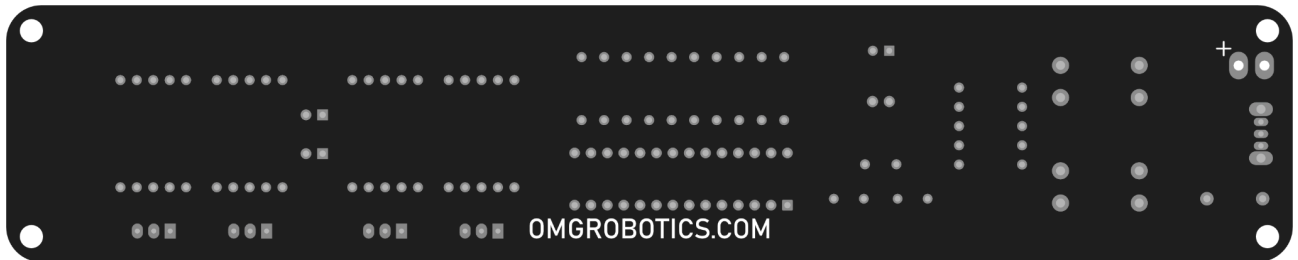

Integrated Circuit

Now insert the **microcontroller U1**.

As when soldering the socket, **pay attention to the component's orientation**.

The IC package has a notch on one side.

This notch must align with the notch on the socket.



U1

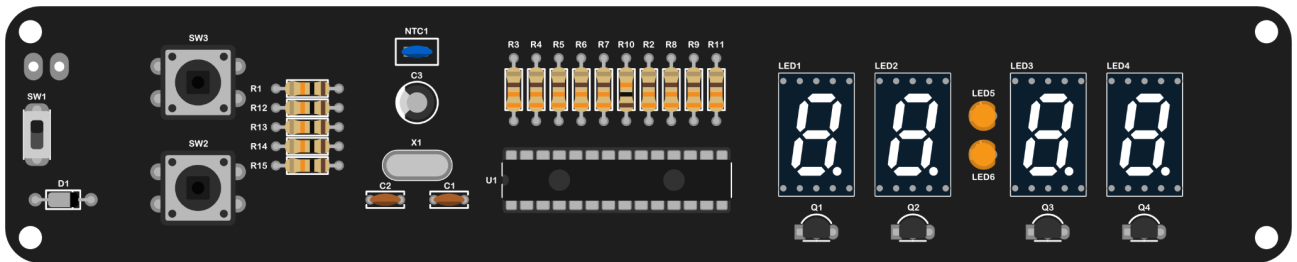
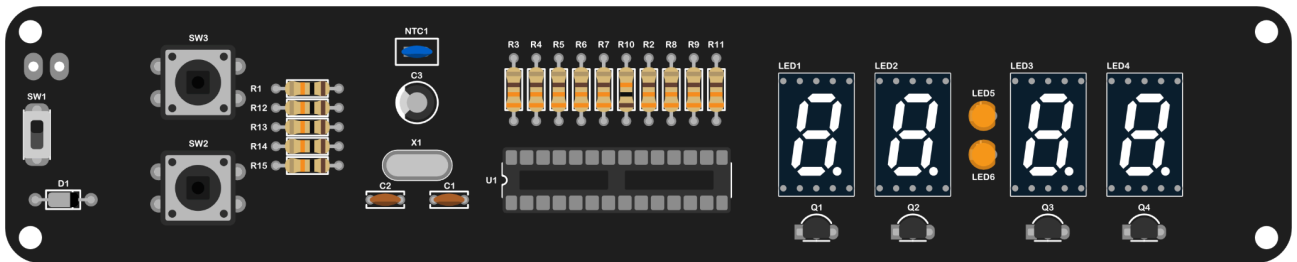

Testing

Now all we need to do is connect the batteries and turn on the **SW1** switch.

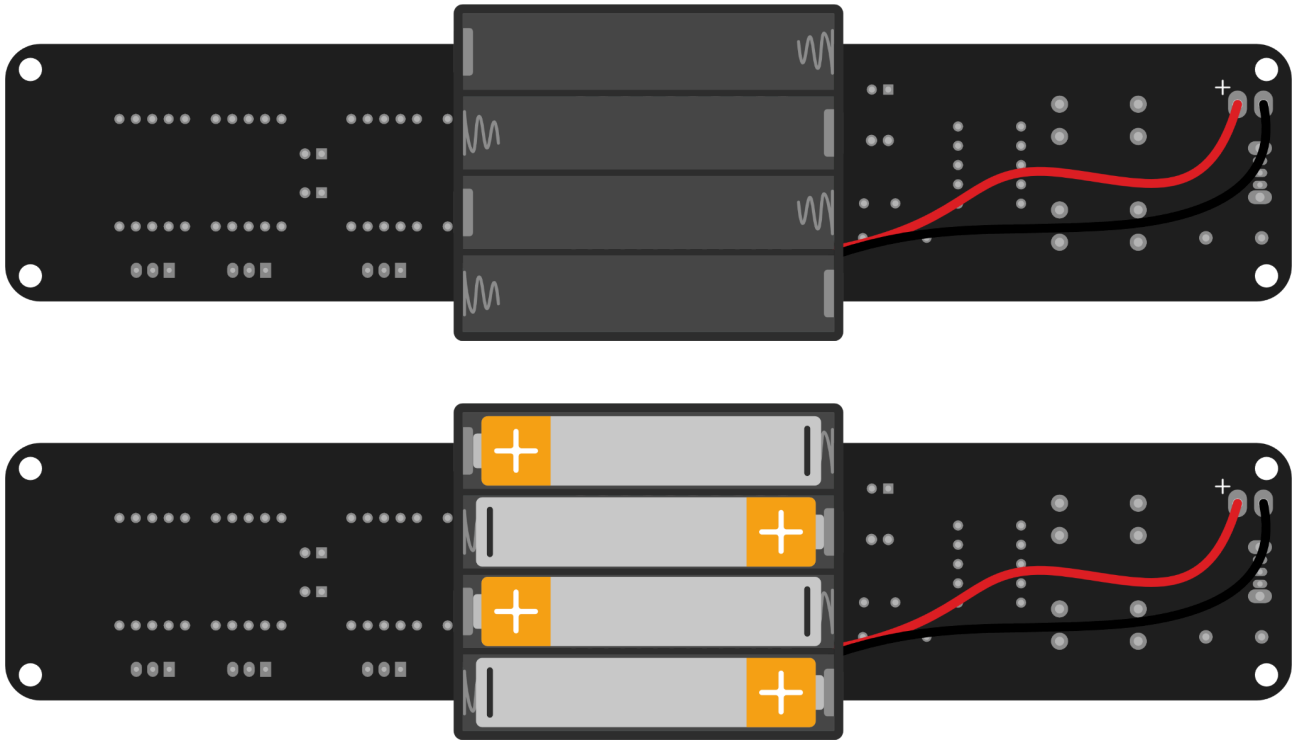

Tips & Troubleshooting

Power-Up

If all steps have been followed correctly, the Christmas tree should work immediately after inserting the batteries and switching it on.

Possible Issues

- **Short circuits** – Two adjacent pins may be accidentally connected, creating an unwanted conductive path.
- **Cold solder joints** – A solder connection may not have been completed properly and lacks electrical contact.
- **Incorrect orientation** – Components may be installed in the wrong direction; check all positions and polarities according to the manual.
- **Misplaced components** – Components may have been installed in the wrong positions (e.g., resistors in incorrect locations).
- **Heat-damaged components** – Some parts may have been damaged by excessive heat during soldering. Identify and replace the affected component.

Instructions

Switching between displays (time, temperature)

After powering on, the set time will light up. To switch to the temperature display, use the upper **SW3** button.

Setting the time

Hold down the lower **SW2** button to access the time settings. Press briefly to set the current digit (the one that is brightly lit). Press and hold to select the next digit. Confirm the set time with the upper **SW3** button.